



CHL and CHH Compact Cylinders

*For working pressures up to
100 and 160 bar*

*Catalogue HY07-1180/UK
February 2003*



Introducing the new CH Series

The CH series of compact double-acting hydraulic 'block' cylinders provides a simple, cost-effective means of applying high density force for movements of up to 100mm. The CHL range employs a one-piece extruded aluminium body and is suitable for working pressures up to 100 bar. The heavier-duty CHH cylinder uses a one-piece steel body and may be used for working pressures of up to 160 bar. Stroke lengths are offered in fixed increments up to a maximum of 100mm; non-standard strokes are available on request.

Design Features and Benefits

1 Rigid, Low Maintenance Construction

Parker's compact cylinders feature an elegant, one-piece cylinder body design, machined to form an integral end cap. A large diameter copper alloy gland closes the head end of the cylinder and houses the gland seals.

- exceptional rigidity – for long, reliable service life
- leakage resistant – a minimum of pressurized joints
- low maintenance requirements

2 Easy to Mount

CHL and CHH cylinders feature counter-bored, through-hole mountings for head or cap end fixing (T-mount). CHH cylinders are also available with foot mounting (C-mount).

- head or cap fixing to suit pull or push applications
- integral keyway and key on foot-mounted cylinders eliminates shear forces on mounting bolts

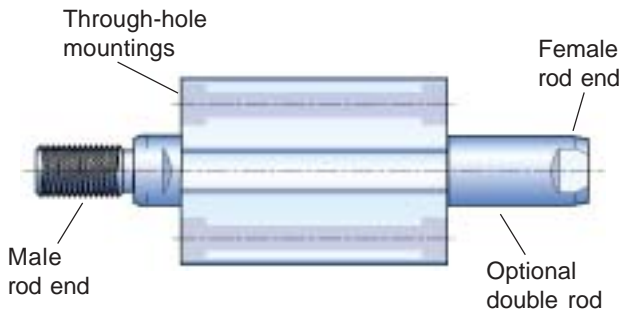

3 Easy to Connect

Male and female threaded rod ends are available as standard.

- permits direct attachment to machine
- simplifies use of custom rod end attachments

4 Single and Double Rod Construction

The functionality of the standard single rod cylinder can be enhanced by choosing the double rod option.

- simple, cost-effective operation of control mechanisms
- direct, reliable operation of safety guards

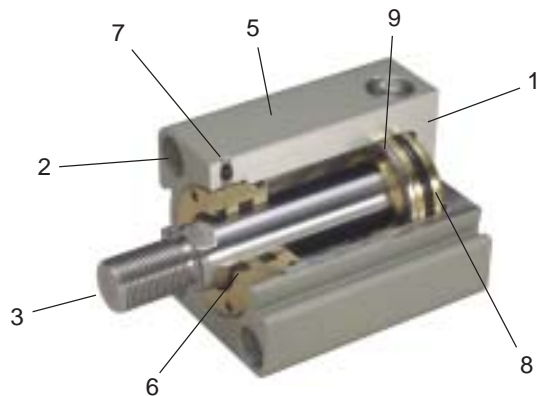

5 Durable, Corrosion-Resistant Finishes

Standard CHH models feature a tough, black oxide coating, while CHL cylinders are finished in anodized aluminium.

- external surfaces require no protection or maintenance
- easy removal and disassembly – even after years in a harsh environment.

6 High Performance Gland Seals

- nitrile wiper and lipseals for low breakout, low friction performance with long working life
- double-lipped wiper ensures that external contaminants remain outside the cylinder – maximising gland and piston seal life
- high resistance to fluid contamination – long system life

7 Vibration-Resistant Gland

The copper alloy gland is secured in position by a urethane locking element.

- gland assembly remains tight and leakproof, even in high-frequency applications.

8 Rugged Piston and Rod Assembly

- pistons are screwed to the rod, threadlocked and pinned – for total security in high frequency applications
- piston rods are hard chrome plated, carbon steel – for high resistance to physical damage
- seal life is maximised – so maintenance is reduced

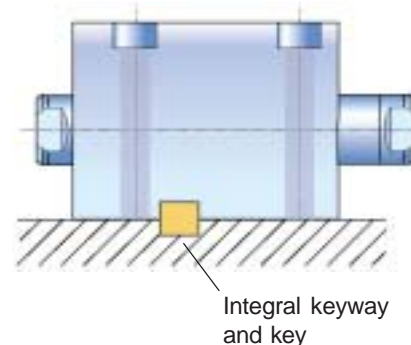

9 Integrated Position Sensing

A magnetic element is incorporated into the piston of all standard CHL models – full position sensing requires only the addition of external sensors. Position sensing is available on CHH models as an optional feature, using a magnetic piston element and stainless steel body.

- flexible, fully adjustable position sensing
- operates at full rated pressure
- optional sensors can be retro-fitted to CHL models without disturbing the cylinder

Typical Applications

Compact or 'block' cylinders are widely used in machine tool applications for clamping and workholding functions. Compact and easily mounted, they can operate across or against cutter force. Their double-acting operation is ideally suited to cycle-dependent applications where functions such as clamping and unclamping have to be completed within a fixed time period.

Optional Features

Robust, Integrated Switching

All face-mounted (T-mount) CH series cylinders are available with piston position-sensing switches which engage with the slotted channels in the sides of the cylinder body. The compact design of the switch allows the connectors to overlap, permitting switches to be placed close together as shown. Alternatively, switches can be positioned on opposite sides of the cylinder, allowing switching zones to overlap if required.

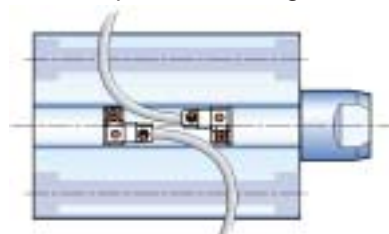

Resistance to Cutting Oil

All CH series cylinders are available in cutting oil-resistant versions. These employ sealing materials which are unaffected by exposure to cutting oil, in liquid or mist form, and feature a wiper seal which prevents seepage of fluid from the external operating environment into the cylinder.

Standard Specifications

Working pressure

Piston speed

Maximum push force (80mm bore)

Cylinder body material – standard
– with optional switch function

Magnetic piston for switch function

Available mounting styles

Operating temperature – standard
– with optional switch function

Recommended fluid

Stroke tolerance

CHL

3.4 – 100 bar

0.008 – 0.10m/s

50.3kN

anodized aluminium
anodized aluminium
standard

front & rear faces

-10°C to +70°C
-10°C to +70°C

mineral oil

0 – 0.8mm

CHH

3.4 – 160 bar

0.008 – 0.10m/s

80.4kN

black oxide steel
stainless steel
optional

front & rear faces, foot mount

-10°C to +100°C
-10°C to +70°C

mineral oil

0 – 0.8mm

CHL Standard Cylinder Availability

Type	Mounting Style	Bore	Available Stroke Lengths												
			5	10	15	20	25	30	40	50	60	70	80	90	100
CHL Single Rod	Face Mount - T	32	●	●	●	●	●	●	●	●	●	●	●	●	●
		40	●	●	●	●	●	●	●	●	●	●	●	●	●
		50	●	●	●	●	●	●	●	●	●	●	●	●	●
		63	●	●	●	●	●	●	●	●	●	●	●	●	●
		80	●	●	●	●	●	●	●	●	●	●	●	●	●
CHL Double Rod	Face Mount - T	32	●	●	●	●	●	●	●	●	●	●	●	●	●
		40	●	●	●	●	●	●	●	●	●	●	●	●	●
		50	●	●	●	●	●	●	●	●	●	●	●	●	●
		63	●	●	●	●	●	●	●	●	●	●	●	●	●
		80	●	●	●	●	●	●	●	●	●	●	●	●	●

Notes

All dimensions are in millimetres unless otherwise specified.
All CHL cylinders are available in cutting oil resistant versions
All CHL cylinders are available with switches

The minimum stroke length with one switch – 5mm; with two switches – 10mm

CHH Standard Cylinder Availability

Type	Mounting Style	Bore	Available Stroke Lengths													
			5	10	15	20	25	30	40	50	60	70	80	90	100	
CHH Single Rod	Face Mount - T	20 ¹	●	●	●	●	●	●	●	●	●					
		25 ¹	●	●	●	●	●	●	●	●	●					
		32	●	●	●	●	●	●	●	●	●	●	●	●	●	●
		40	●	●	●	●	●	●	●	●	●	●	●	●	●	●
		50	●	●	●	●	●	●	●	●	●	●	●	●	●	●
		63	●	●	●	●	●	●	●	●	●	●	●	●	●	●
	80	●	●	●	●	●	●	●	●	●	●	●	●	●	●	
	Foot Mount - C	32 ²	●	●	●	●	●	●	●	●	●					
		40 ²	●	●	●	●	●	●	●	●	●					
		50 ³	●	●	●	●	●	●	●	●	●					
63 ³		●	●	●	●	●	●	●	●	●						
CHH Double Rod	Face Mount - T	20 ¹	●	●	●	●	●	●	●	●						
		25 ¹	●	●	●	●	●	●	●	●	●					
		32	●	●	●	●	●	●	●	●	●	●	●	●	●	●
		40	●	●	●	●	●	●	●	●	●	●	●	●	●	●
		50	●	●	●	●	●	●	●	●	●	●	●	●	●	●
		63	●	●	●	●	●	●	●	●	●	●	●	●	●	●
	80	●	●	●	●	●	●	●	●	●	●	●	●	●	●	
	Foot Mount - C	32 ²	●	●	●	●	●	●	●	●	●					
		40 ²	●	●	●	●	●	●	●	●	●					
		50 ³	●	●	●	●	●	●	●	●	●					
63 ³		●	●	●	●	●	●	●	●	●						

All dimensions are in millimetres unless otherwise specified.

¹ 20mm and 25mm bore cylinders are not available with SAE ports

² 32mm and 40mm bore C mount cylinders are not available with SAE ports

³ 50mm and 63mm bore cylinders with SAE ports are available to special order

Ordering Example

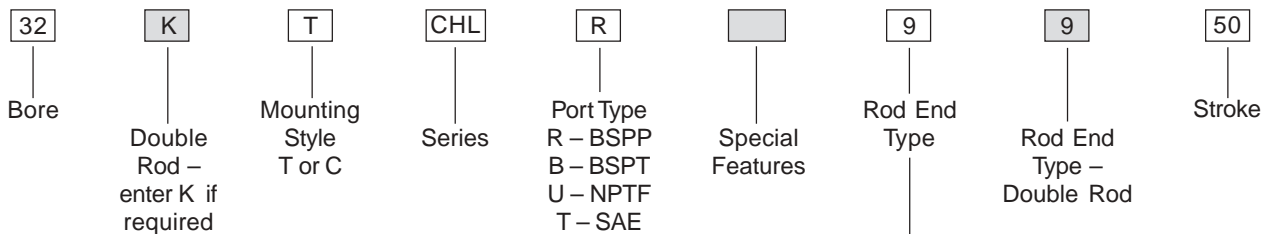

Key
 Required for basic cylinder
 Indicate optional features or leave blank

Code	Rod End
8	Male
9	Female
5	Long male
3	Special



Parker Hannifin plc
 European Cylinder Division
 6 Greycaine Road
 Watford, Herts. WD24 7QA
 Tel. 01923 492 000
 Fax 01923 248 557
 www.parker.com/uk

Catalogue HY07-1180/UK
 1M 02/03 PD

© Copyright 2003
 Parker Hannifin plc
 All rights reserved.